

Gallery

Explore Memphis

Memphis: Plastic Field Family Guide

Who were Memphis?

Memphis were a group of designers who, in the early 1980's, made furniture, lighting, fabrics, ceramics, glass and metal objects. The group had members from all around the world.

Many objects in the 20th century were designed because of how they worked over how they looked. But Memphis wanted to design objects, which were fun and playful as well as functional. They became known for their bright colours, bold patterns and geometric shapes.

The Memphis group lasted for only 7 years but their influence helped set the trends of the 1980's. This could be seen on television programmes like MTV and Saved by the Bell. You can see examples of their influence in our Reading Room.

Colour me in

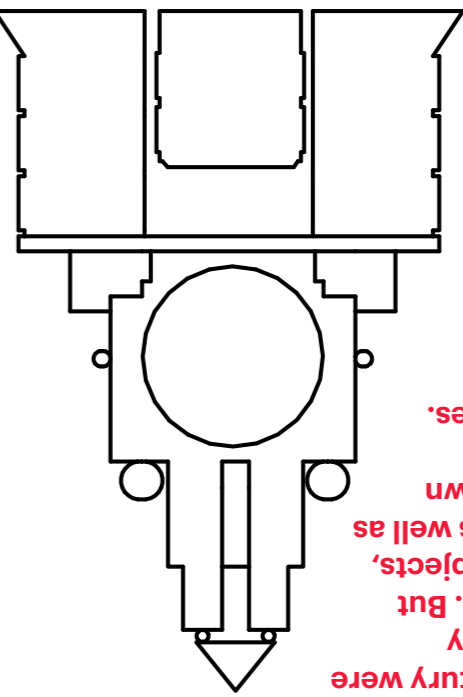

↓ Memphis objects were often decorated in bold patterns.

Decorate Kristall by Michele De Lucchi using the pattern above (Zambia by Nathalie Du Pasquier) or design your own pattern.

→ As you move through the galleries you will see that all of the artworks are arranged on a floor plan made up of Memphis patterns.

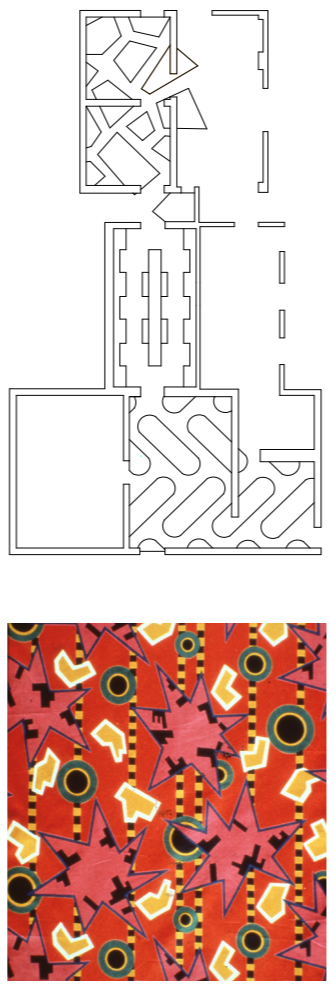

Nathalie Du Pasquier, Zambia 1982

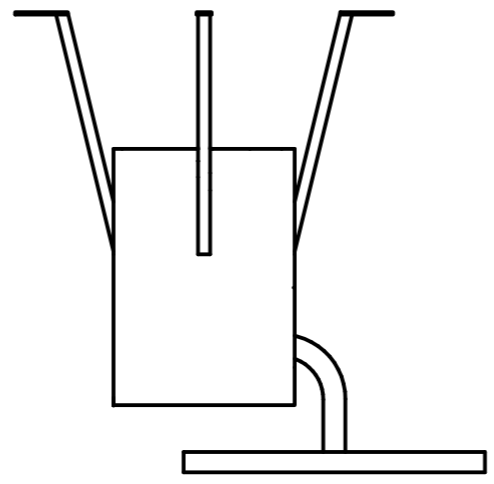

↘ Can you find Super lamp designed by Martine Bedin?



Martine Bedin, Super Lamp 1981

Martine Bedin wanted to design something she could take with her anywhere, so she added wheels to her lamp design. "I can carry it behind me, like a dog," she said.

The design of the Super, which looks a bit like a stegosaurus, was one of 'the more funny ones' (Martine Bedin)

Which piece is your favourite?

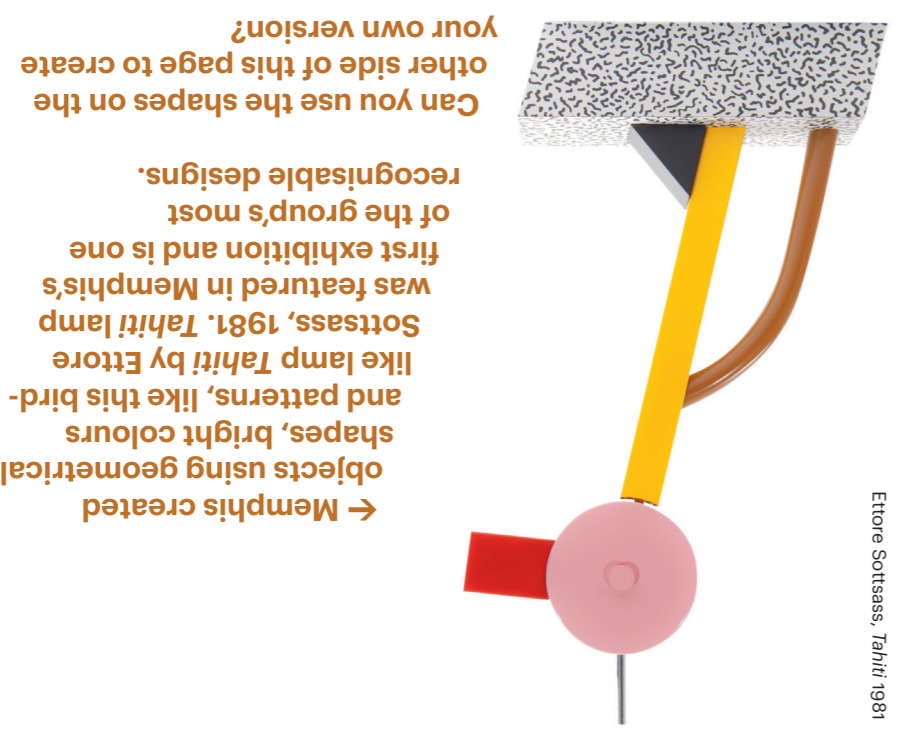

Ettore Sottsass, Tahiti 1981

↪ Memphis created objects using geometrical shapes, bright colours and patterns, like this bird-like lamp Tahiti by Ettore Sottsass, 1981. Tahiti lamp was featured in Memphis's first exhibition and is one of the group's most recognisable designs.

Can you use the shapes on the other side of this page to create your own version?

↪ Memphis created objects using geometrical shapes, bright colours and patterns, like this bird-like lamp Tahiti by Ettore Sottsass, 1981. Tahiti lamp was featured in Memphis's first exhibition and is one of the group's most recognisable designs.

Can you use the shapes on the other side of this page to create your own version?

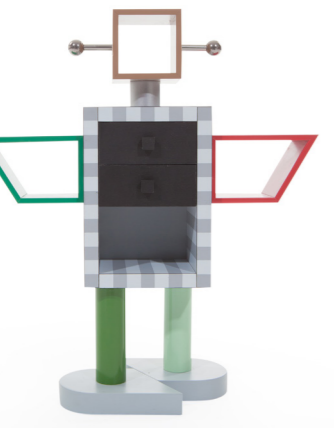

Masanori Umeda, Girza 1982
Ettore Sottsass, Carlton 1981

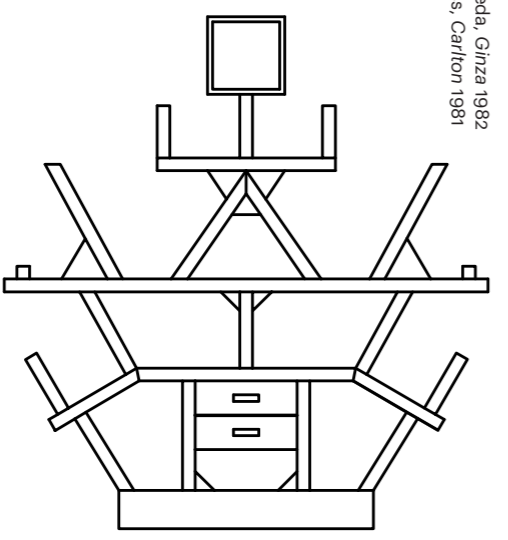

Colour in this drawing of Carlton by Ettore Sottsass in the colours you see. ↘



Memphis designer Martine Bedin asked 'Can we imagine a new world by drawing another chair, another table, another light, another vase?'

Use this page to design your own Memphis inspired piece of furniture. Remember to use lots of bright colours, geometric shapes and bold patterns.

**Can you name all of the shapes and colours?
Cut out the shapes to make a lamp like Tahiti,
or use the shapes to design your own.**

